

Installation manual

Montageanleitung • Notice de montage • Istruzioni per il montaggio • Manual de montaje • Monteringsanvisning •
Installatiegids • Montážní návod • Asennusohje • Installationsmanual

Log cabin FRD34-3548

Blockhaus • Maisonnette en poutres • Casa di travi • Casa de jardin • Anneks • Tuinhuis • Zahradní domek •
Timmerstuga • Hirsimökki

Width 350 x Depth 480 cm











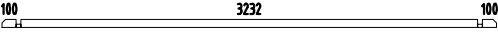
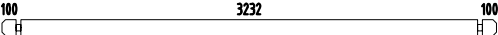
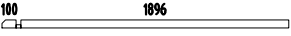

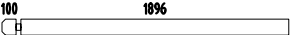
Breite/Tiefe • Largeur/Profondeur • Lunghezza/Profondità • Ancho/Profundidad • Bredde/Dybde • Breedte/Diepte
• Šířka/Hloubka • Leveys/Pituus • Bredd/Längd





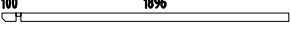

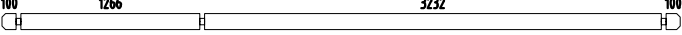
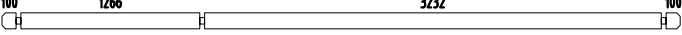
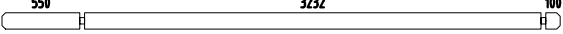
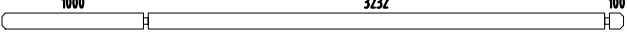
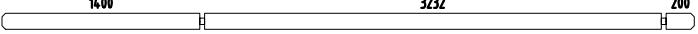
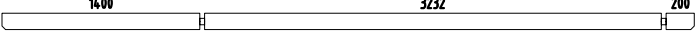
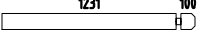
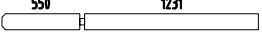
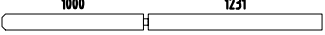
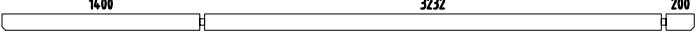
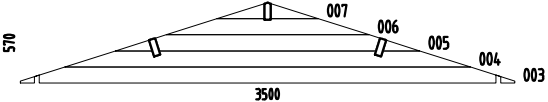



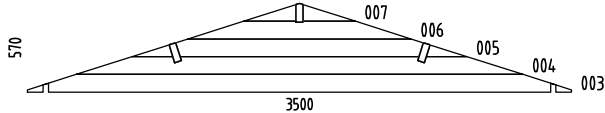



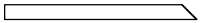





Log thickness 34 mm

Bohlenstärke • Épaisseur des murs • Spessore delle pareti • Grosor de pared • Tykkelse • Wanddicke • Tloušťka
stěny • Seinän paksuus • Väggtjocklek





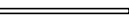
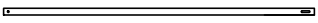





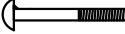



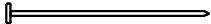

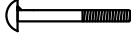
The producer shall have the right to make technical changes to the product • Technische Änderungen vorbehalten • Le
producteur réserve le droit d'effectuer des modifications techniques au produit • Il produttore mantiene il diritto di apportare
modifiche tecniche al prodotto • Reservado el derecho a modificaciones técnicas • Produsent forbeholder seg retten til å endre
tekniske egenskaper ved produktet • Alle rechten en technische wijzigingen voorbehouden • Výrobce si vyhrazuje právo na
technické změny výrobku • Valmistaja pidättää oikeuden tehdä tuotteeseen teknisiä muutoksia • Tillverkaren har rätt att utföra
tekniska förändringar för produkten

| Pos | SPECIFICATION-STÜCKLISTE-NOMENCLATURE-ELEMENTI-ESPECIFICACIÓN -Harriet- | Pcs | Profile (mm) | Length (mm) |
|---|--|-----|-----------------|----------------|
| 001 |  | 1 | 34x57 | 3500 |
| 002 |  | 31 | 34x114 | 3500 |
| 008 |  | 2 | 34x57 | 2030 |
| 009 |  | 2 | 34x57 | 630 |
| 010 |  | 10 | 34x114 | 2030 |
| 011 |  | 31 | 34x114 | 630 |
| 012 |  | 9 | 34x114 | 630 |
| 013 |  | 9 | 34x114 | 234 |
| 014 |  | 3 | 34x114 | 470 |
| 015 |  | 3 | 34x114 | 234 |
| 016 |  | 1 | 34x57 | 2030 |
| 017 |  | 1 | 34x57 | 630 |
| 018 |  | 6 | 34x114 | 4800 |
| 019 |  | 2 | 34x114 | 4800 |
| 020 |  | 1 | 34x114 | 3950 |
| 021 |  | 1 | 34x114 | 4400 |
| 022 |  | 2 | 34x114 | 4900 |
| 023 |  | 1 | 34x114 | 4900 |
| 024 |  | 16 | 34x114 | 1365 |
| 025 |  | 1 | 34x114 | 1815 |
| 026 |  | 1 | 34x114 | 2265 |
| 027 |  | 1 | 34x114 | 4900 |
| W1-1 |  | 1 | | |
|  Object name -Harriet- | | | Page 1/3 | |

| Pos | SPECIFICATION-STÜCKLISTE-NOMENCLATURE-ELEMENTI-ESPECIFICACIÓN FRD34-3548 | Pcs | Profile (mm) | Length (mm) |
|------|--|-----|-----------------|----------------|
| W2-1 |  | 1 | | |
| AR1 | Foundation- Fundament- Fondation- Fondazione- Vigas de cimentación  | 7 | 70x45 | 4450 |
| AR2 | Foundation- Fundament- Fondation- Fondazione- Vigas de cimentación  | 2 | 70x45 | 3290 |
| AR3 | Foundation- Fundament- Fondation- Fondazione- Vigas de cimentación  | 3 | 70x45 | 467 |
| RA11 | Railing board- Geländer- Barre de rambarde- Tavola di ringhiera- Tabla de barandilla  90°/45° | 1 | 19x95 | 1980 |
| RA13 | Railing board- Geländer- Barre de rambarde- Tavola di ringhiera- Tabla de barandilla  90°/45° | 2 | 19x95 | 1235 |
| RA12 | Railing board- Geländer- Barre de rambarde- Tavola di ringhiera- Tabla de barandilla  90°/45° | 1 | 19x95 | 580 |
| PR1 | Purlin- Dachpfette- Arbaletrier- Arcareccio- Correa  | 2 | 44x140 | 4900 |
| PR2 | Purlin- Dachpfette- Arbaletrier- Arcareccio- Correa  | 1 | 44x140 | 4900 |
| 060 | Floor board- Fussbodenbrett- Madrier du plancher - Tavola pavimento- Tabla de suelo  | 38 | 89x19 | 3225 |
| 061 | Terrace board- Terrassenbrett- Madrier de terrace- Tavola terrazzo- Tabla de terraza  | 13 | 95x19 | 3225 |
| 062 | Terrace board- Terrassenbrett- Madrier de terrace- Tavola terrazzo- Tabla de terraza  | 1 | 36x19 | 840 |
| 070 | Roof board- Dachbrett- Madrier du toit- Tavola tetto- Tabla de tejado  | 112 | 89x19 | 2040 |
| 120 | Diamond- Deckbrett- Madrier- Tavola di copertura- Rombo  | 2 | 19x140 | 300 |
| 090 | Eave edging- Dachrandbrett- Madrier en bordure du toit- Tavola bordo tetto- Tabla de valadizo  | 4 | 19x95 | 2450 |
| 100 | Facia board- Giebelblende- Écran frontal- Schermo frontone- Tabla de facia  | 4 | 19x120 | 2080 |
| 130 | Floor beading- Fussbodenleiste- Baguette du plancher- Listello pavimento- Listón de suelo  | 8 | 19x19 | 1710 |
| 080 | Roof edge reinforcement- Dachrandleiste- Baguette en bordure du toit- Rinforzo bordo tetto- Refuerzo borde tejado  | 2 | 32x40 | 1950 |
| 081 | Roof edge reinforcement- Dachrandleiste- Baguette en bordure du toit- Rinforzo bordo tetto- Refuerzo borde tejado  | 2 | 32x40 | 2950 |
| 156 | Slat- Leiste- Baguette- Listello- Listón  | 1 | 19x35 | 840 |
| 140 | Storm brace- Sturmleiste- Protection contre le vent- Antivento- Protector contra tormentas  | 4 | 25x45 | 2000 |
| 170 | U-profile board- U-Profilleiste- Baguette profilée en U- Listello profilo ad U- Listón de perfil U s34  | 2 | 25x55 | 770 |
| | | | | |
| | | | | |

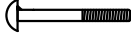

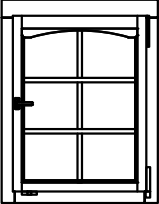
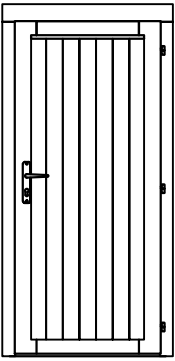
| Pos | SPECIFICATION-STÜCKLISTE-NOMENCLATURE-ELEMENTI-ESPECIFICACIÓN -Harriet- | Pcs | |
|--------|--|--|---|
| 300 | -Fixing kit- Befestigungsset- Moyens de fixation- Materiale di fissaggio- Kit de fijación |  | 1 |
| | Bolt -Schloss-schraube -Boulon- Bullone- Perno- M8x80mm |  | 8 140 |
| | Cylinder- Zylinderschloss- Serrure a mortaiser- Serratura a cilindro- Bombin |  | 1 U34-7R |
| | Door fittings- Türbeschlag- Ferrure- Ferramenta porta- Manilla (puerta) |  | 1 U34-7R |
| | Nail- Nagel- Clou- Chiodo- Clavo- 1.4x40mm |  | 32 130 |
| | Nail- Nagel- Clou- Chiodo- Clavo- 2.5x50mm |  | 750 060; 061; 062; 070; ... |
| | Nail- Nagel- Clou- Chiodo- Clavo- 4x120mm |  | 18 ARx |
| | Nut- Schraubenmutter- Écrou- Dado- Tuerca- M8mm |  | 8  |
| | Screw- Schraube- Vis- Vite- Tornillo- 3.5x40mm |  | 80 080; 090; 100; 120 |
| | Screw- Schraube- Vis- Vite- Tornillo- 3x20mm |  | 12 A-343R |
| | Screw- Schraube- Vis- Vite- Tornillo- 4.5x50mm |  | 15 RA1x |
| | Screw- Schraube- Vis- Vite- Tornillo- 4.5x70mm |  | 20 001; 008; 009; PRx |
| | Washer- Dichtscheibe- Joint- Rondella- Arandela- 8x22mm |  | 8  |
| | Window fittings- Fenstergriff- Poigne de la fenêtre- Maniglia finestra- Manilla (ventana) |  | 2 A-343R |
| MLA283 | Window shutters- Fensterladen- Volets- Imposte della finestra- Contraventana- MLA283 |  | 2 A-343R |
| A-343R | Window - Fenster - Fenetre - Finestra-Ventana 765x990 |  | 2 |
| U34-7R | Door - Tür - Porte - Porta-Puerta 835x1820 |  | 1 |



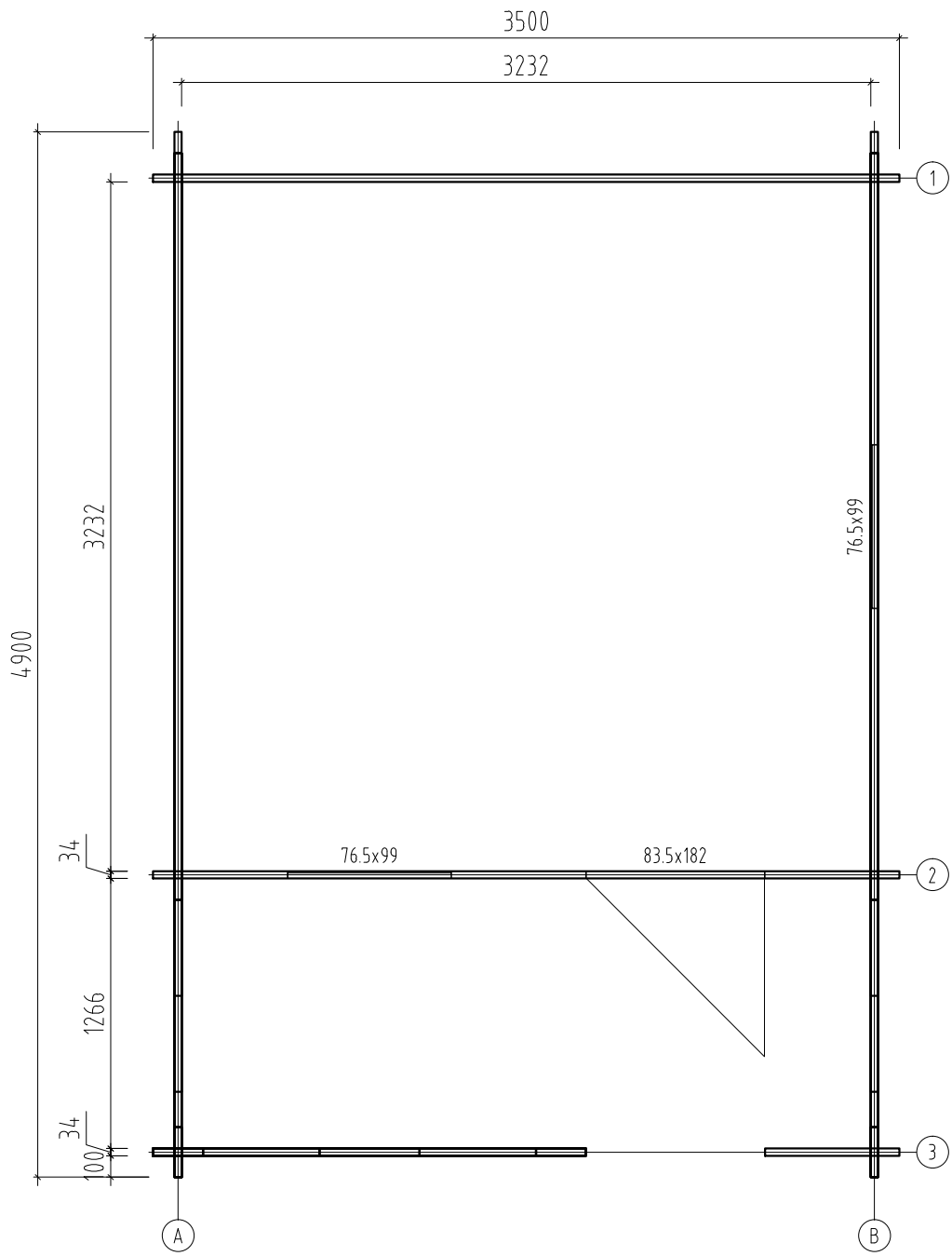

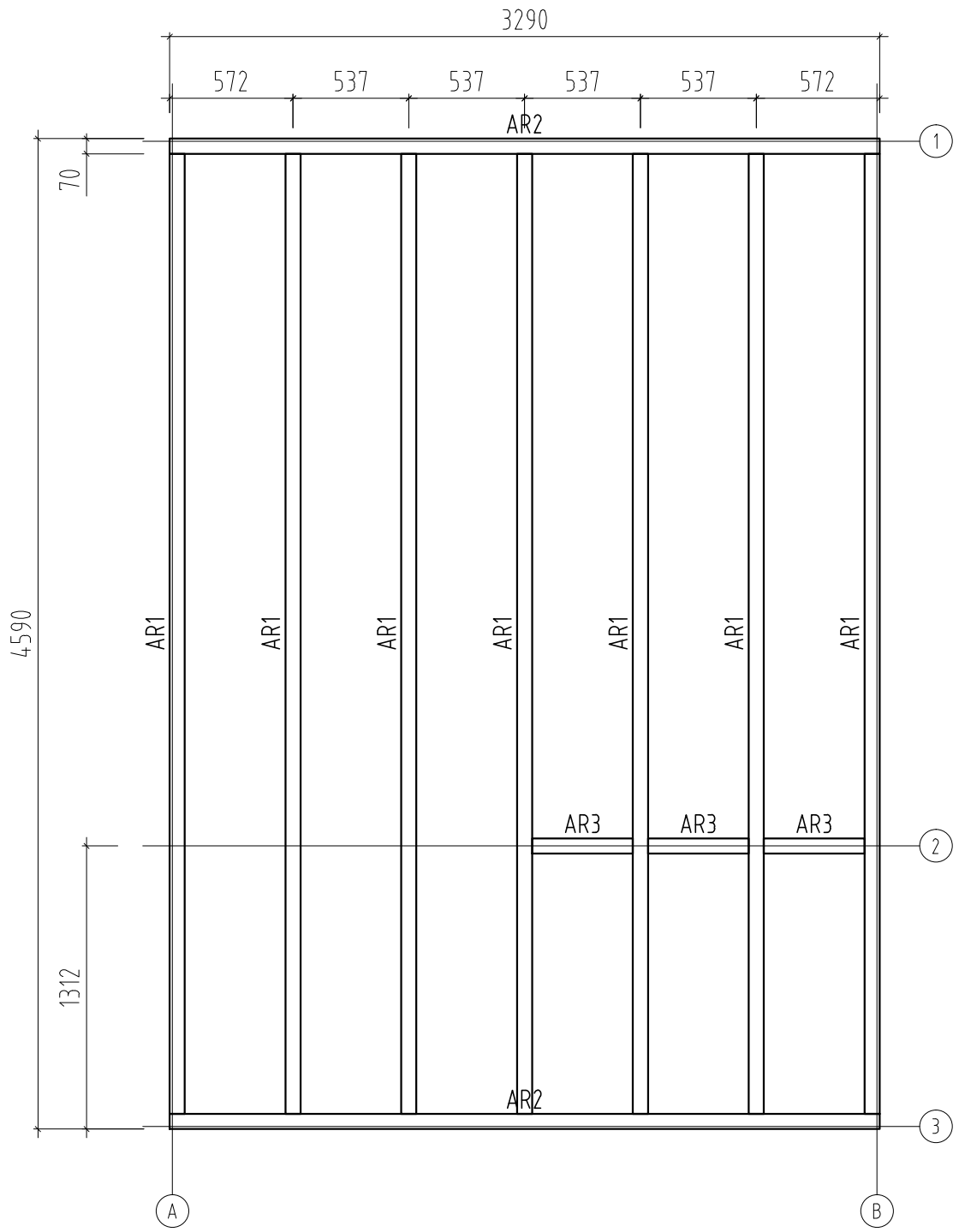

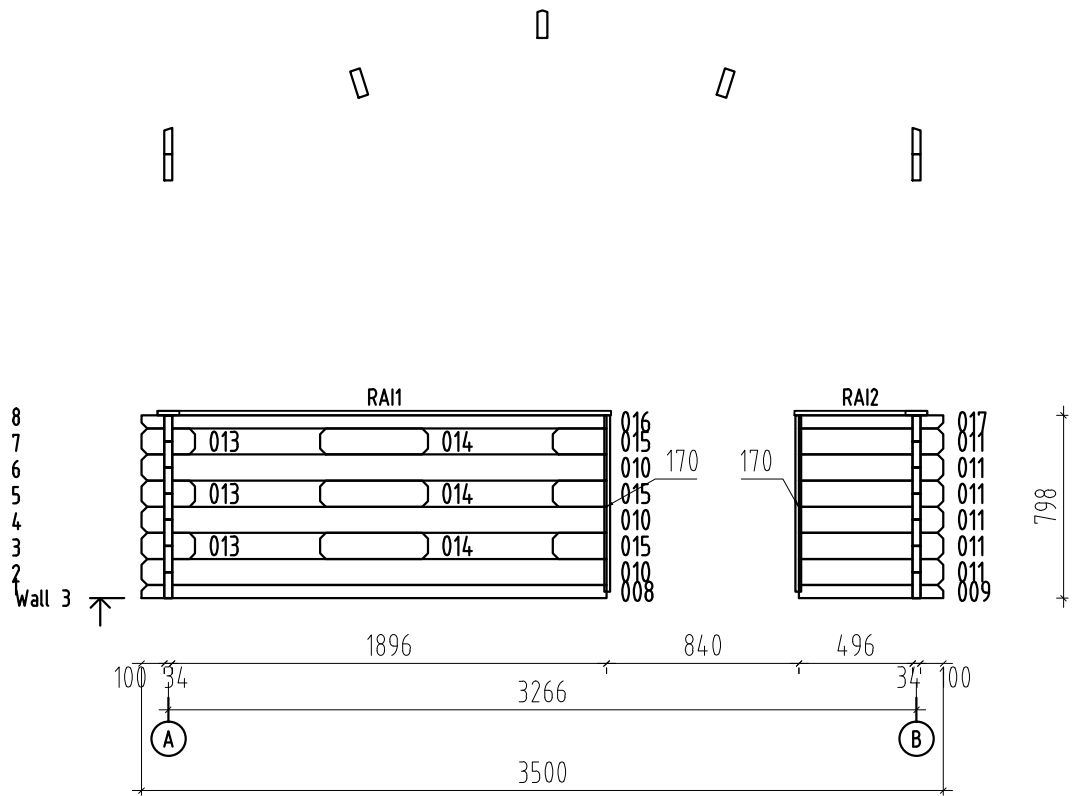

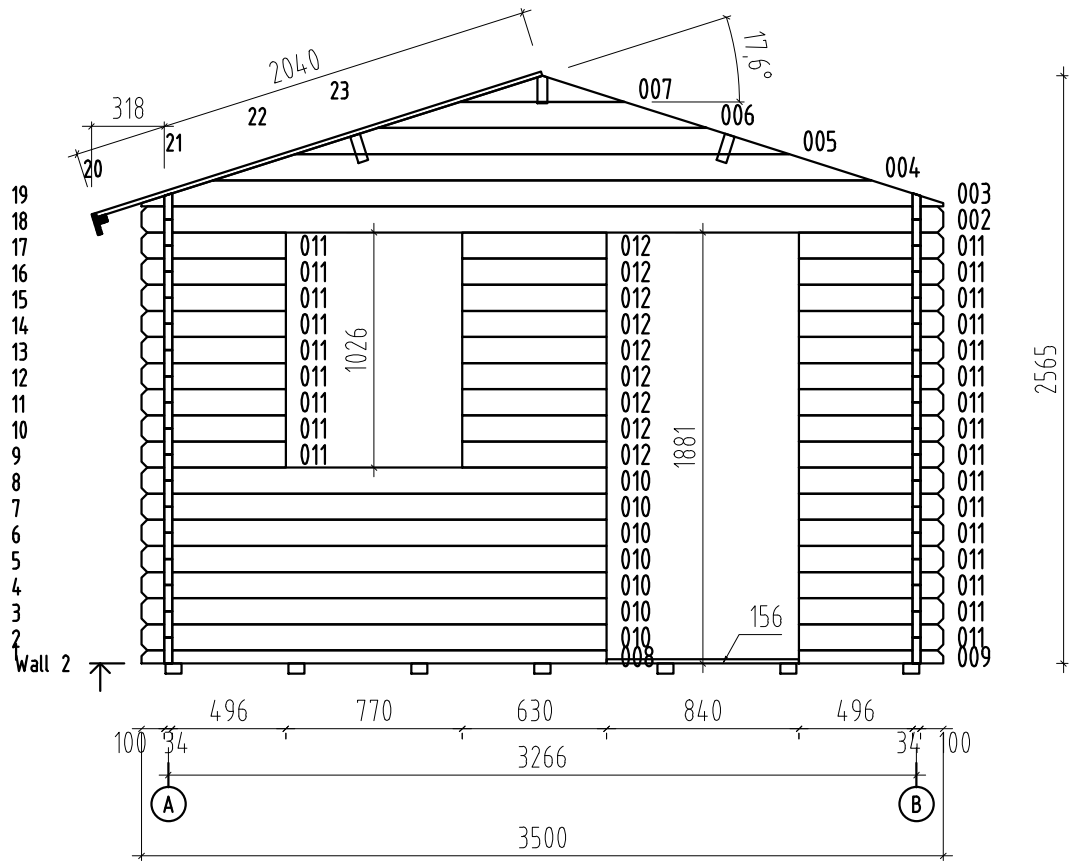

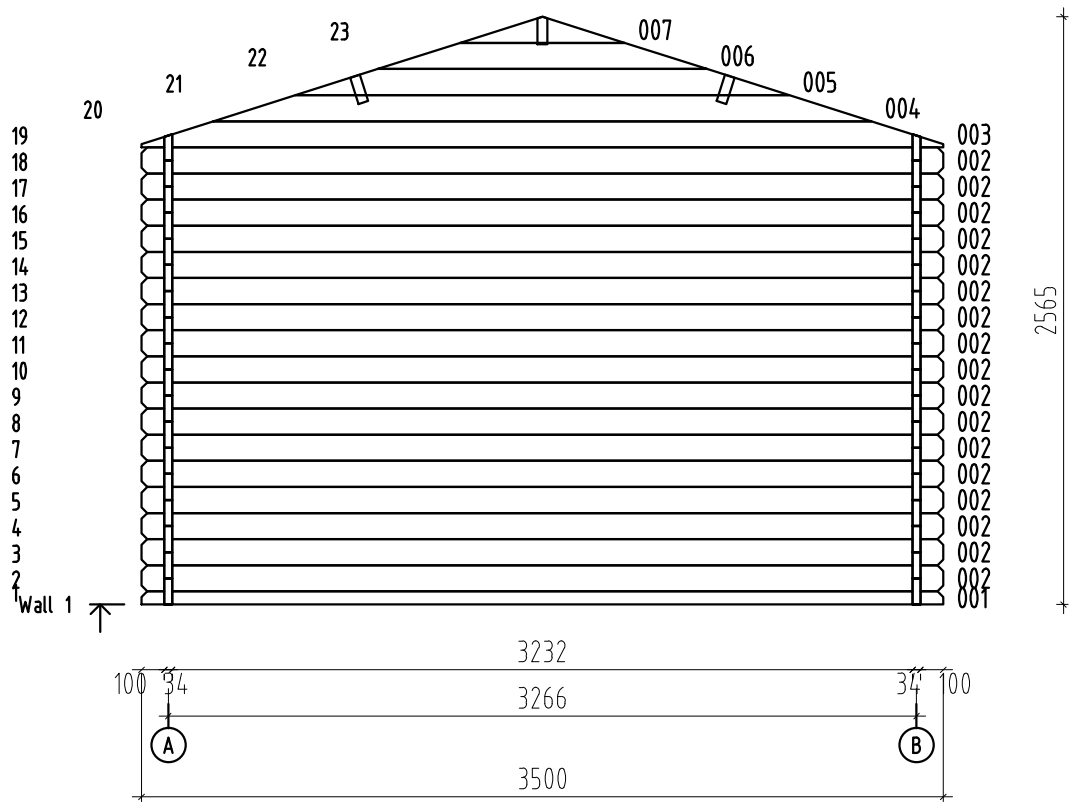

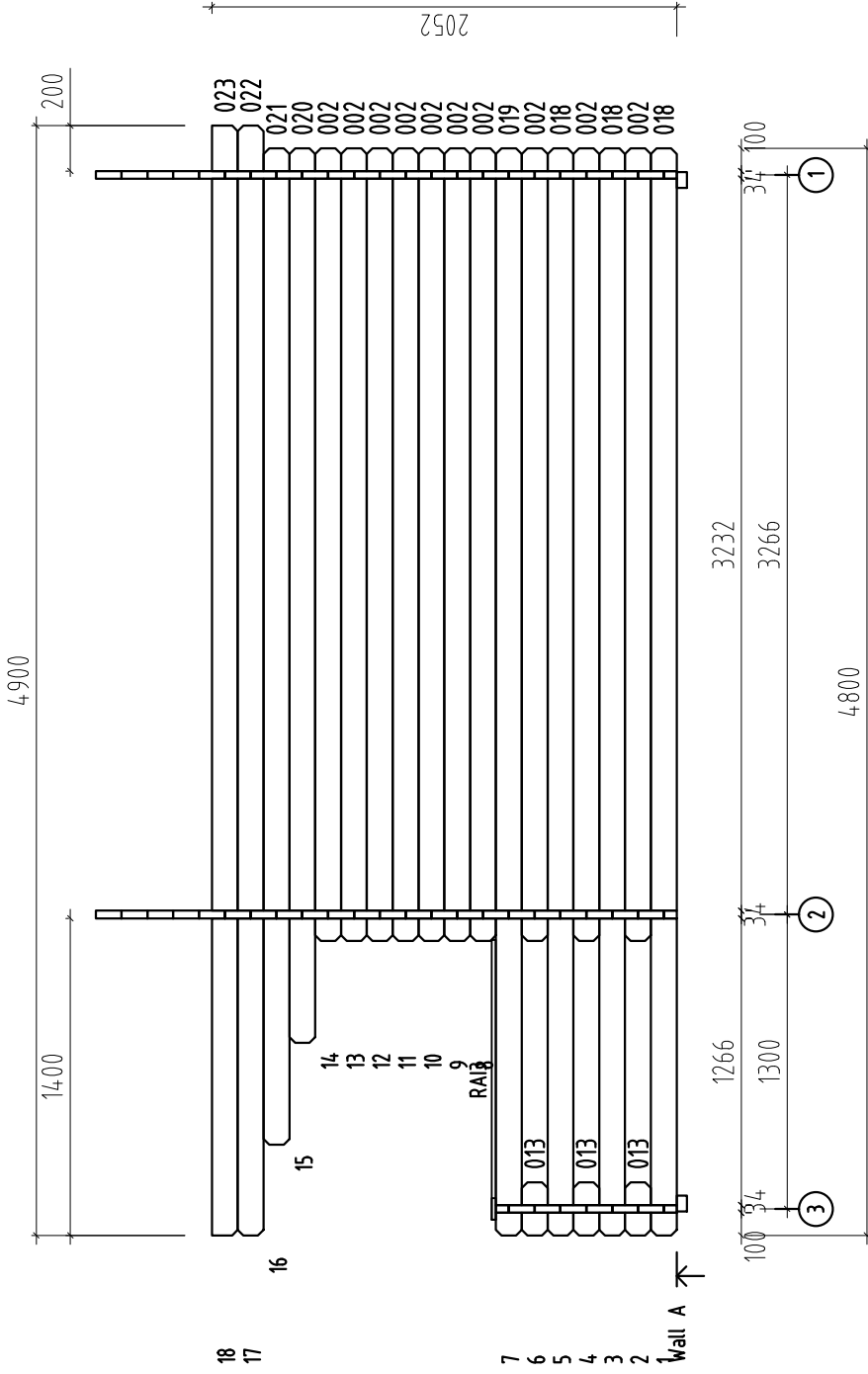

2052

